

MATERIAL BUY-OUT LIST

ITEM #	DESCRIPTION	MAKE / PART NUMBER	QTY	SUPPLIED BY	INSTALLED BY
—	FAUCET	T&S BRASS / B-1120	1	OTHERS	EUROBAR

EB3CS19 - 3 COMP SINK

ITEM ##### - SCALE: #'' = 1'-0''

MATERIALS & FINISHES

(WHERE APPLICABLE)

- **WORKING SURFACE & TUB(S):** 16GA 304 SERIES S/S, #4 FINISH
- **UNDERSTRUCTURE:** 16GA GALVANIZED
- **CABINET BODY & FLOOR SHELF:** 18GA S/S, #4 FINISH
- **LEGS:** ϕ 1-5/8" 16GA S/S TUBING & ADJ. BULLET FEET
- **FAUCET(S):** PROVIDED BY OTHERS, INSTALLED BY EUROBAR
- **DRAIN(S):** BY EUROBAR
- ϕ 1 1/2" BASKET DRAIN, 1 1/2" NPT - QTY (1)
- **MOUNTING CLIPS:** 1 EA PER 24" OF BACKSPLASH

SHIP BUY OUTS TO
FACTORY FOR
INSTALLATION

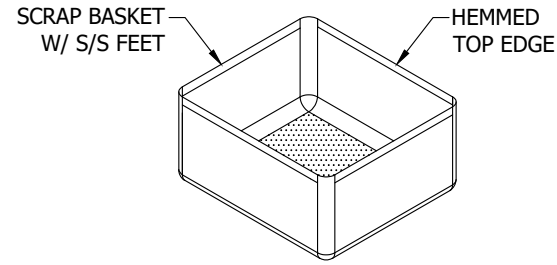

SCRAP BASKET DETAIL

SCALE: N.T.S.

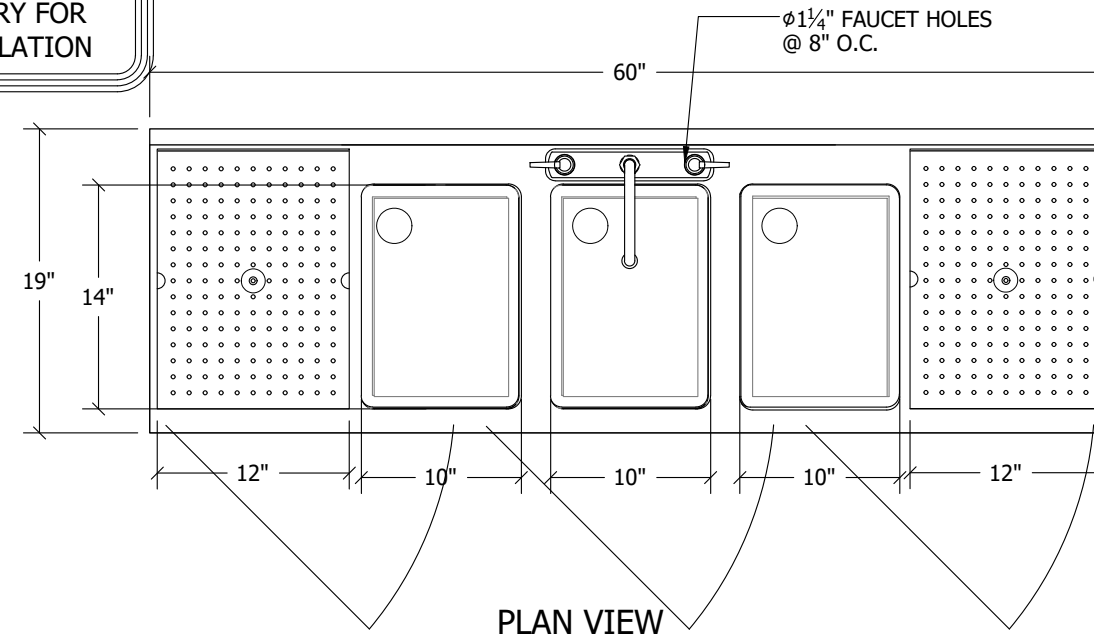

PLAN VIEW

1 EACH

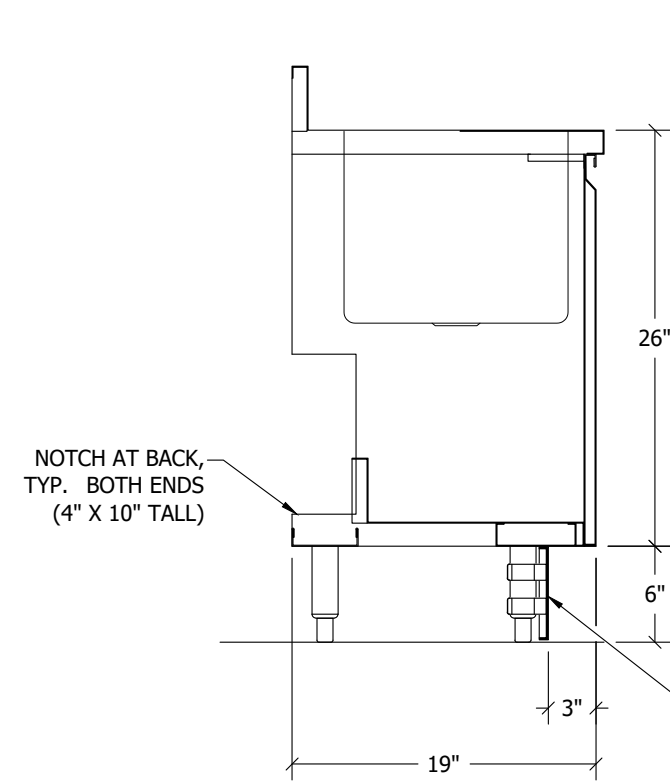

SECTION VIEW

Scale: 1" = 1'-0"

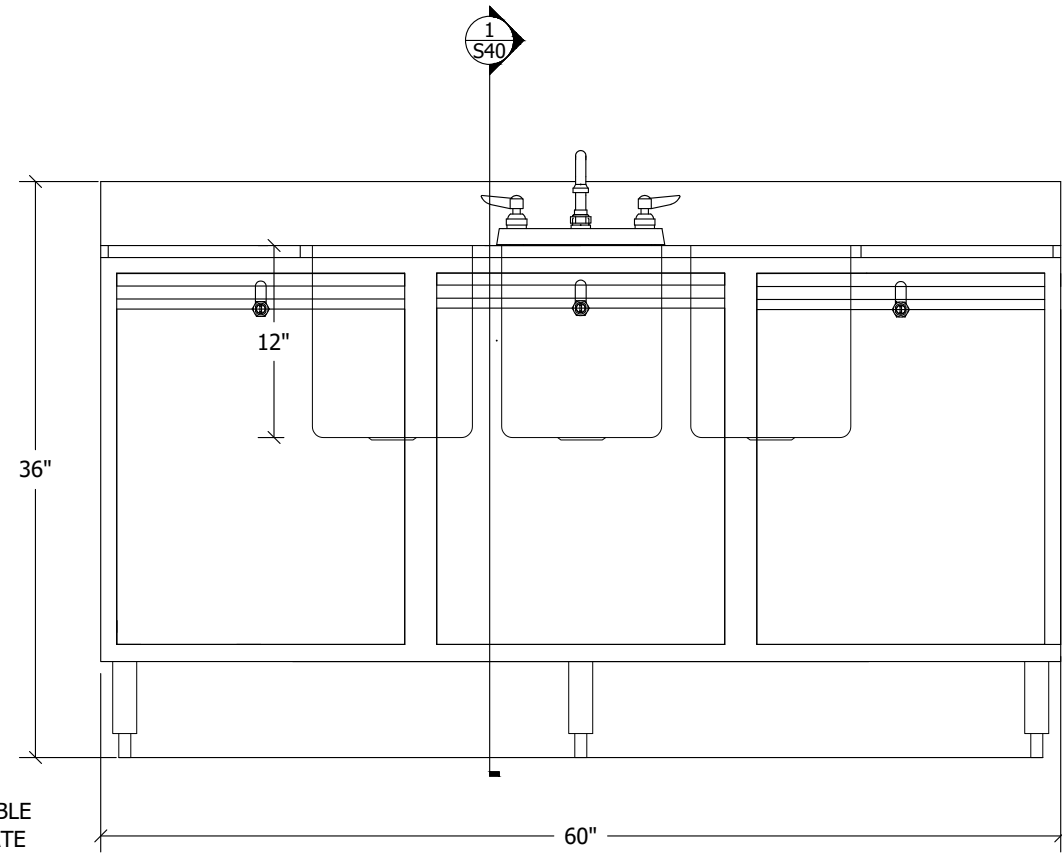

FRONT VIEW

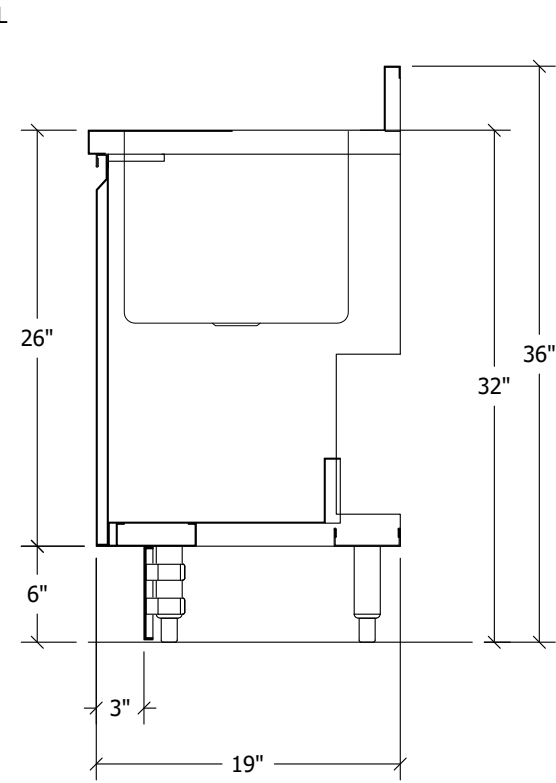

SIDE VIEW

CUSTOMER:

ITEM NO: **EB3CS19**
 MAIN SCALE: **1**
 SECTION SCALE: **1**

40

REVISIONS

NO.	DESCRIPTION	DATE

Proj. Mgr: _____
 Drawn By: _____
 Drawn Date: _____