

SHIP BUY OUTS TO
FACTORY FOR
INSTALLATION

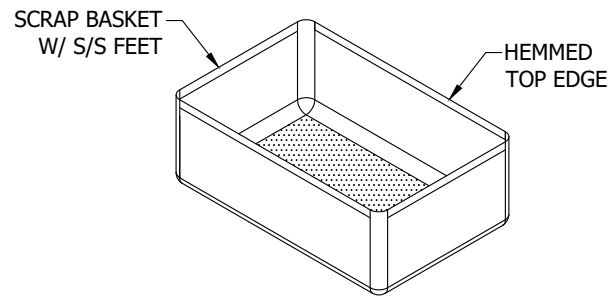

SCRAP BASKET DETAIL
SCALE: N.T.S.

MATERIAL BUY-OUT LIST					
ITEM #	DESCRIPTION	MAKE / PART NUMBER	QTY	SUPPLIED BY	INSTALLED BY
—	FAUCET	T&S BRASS / B-1110	1	OTHERS	EUROBAR

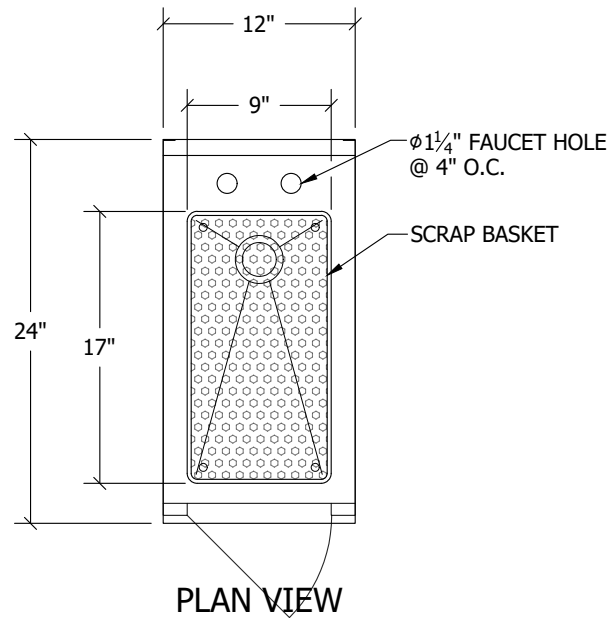

EBDS12 - DUMP SINK
ITEM ##### - SCALE: # " = 1'-0"

MATERIALS & FINISHES
(WHERE APPLICABLE)

- WORKING SURFACE & TUB(S): 16GA 304 SERIES S/S, #4 FINISH
- UNDERSTRUCTURE: 16GA GALVANIZED
- CABINET BODY & FLOOR SHELF: 18GA S/S, #4 FINISH
- LEGS: φ1-5/8" 16GA S/S TUBING & ADJ. BULLET FEET
- FAUCET(S): PROVIDED BY OTHERS, INSTALLED BY EUROBAR
- DRAIN(S): BY EUROBAR
 - φ1 1/2" BASKET DRAIN, 1 1/2" NPT - QTY (1)
- MOUNTING CLIPS: 1 EA PER 24" OF BACKSPLASH

1 EACH

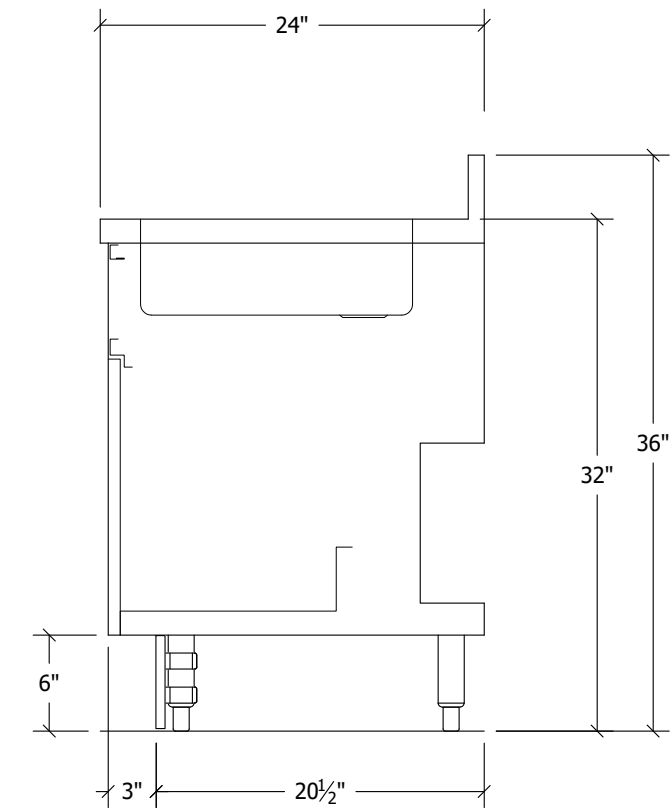
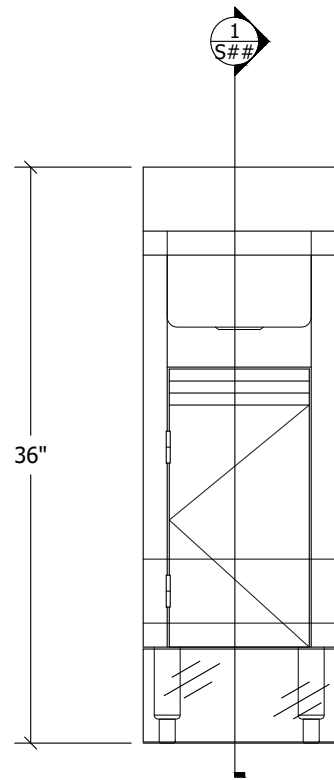
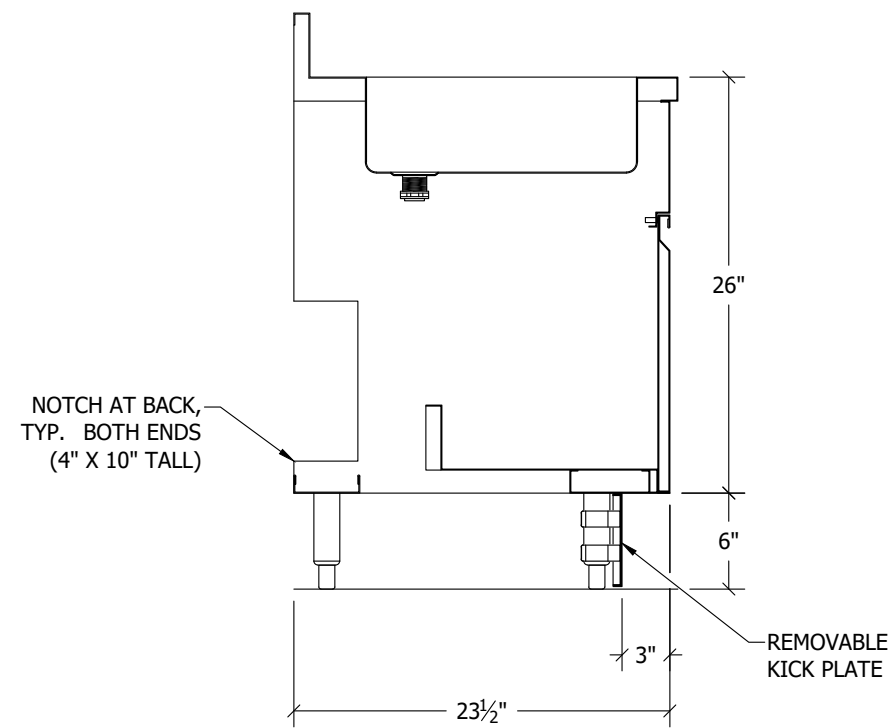

CUSTOMER:

ITEM NO: EBDS12
MAIN SCALE: 1
SECTION SCALE: 1

EUROBAR
MASTER DRAWING
11x17 PAGE FORMAT

17

REVISIONS

Proj. Mgr:
Drawn By:
Drawn Date: