

MATERIAL BUY-OUT LIST					
ITEM #	DESCRIPTION	MAKE / PART NUMBER	QTY	SUPPLIED BY	INSTALLED BY
—	14" S/S DRAWER SLIDES	CHG / S26-0014	1	EUROBAR	EUROBAR

EBFSU15 - WORK STATION
ITEM ## - SCALE: # = 1'-0"

MATERIALS & FINISHES
(WHERE APPLICABLE)

- **WORKING SURFACE:** 16GA 304 SERIES S/S, #4 FINISH
- **UNDERSTRUCTURE:** 16GA GALVANIZED
- **CABINET BODY:** 18GA S/S, #4 FINISH
- **DRAWER(S):** 18GA S/S, #4 FINISH
- **SOUND DEADEN UNDERCOAT REQUIRED AT BOTTOM OF DRAWER PAN ONLY (SEE NOTE BELOW)**
- **LEGS:** ϕ 1-5/8" 16GA S/S TUBING & ADJ. BULLET FEET
- **MOUNTING CLIPS:** 1 EA PER 24" OF BACKSPLASH

1 EACH

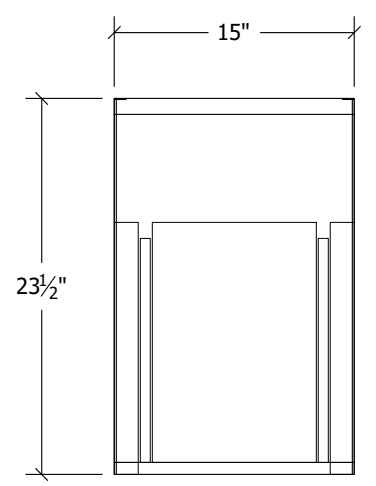

PLAN VIEW

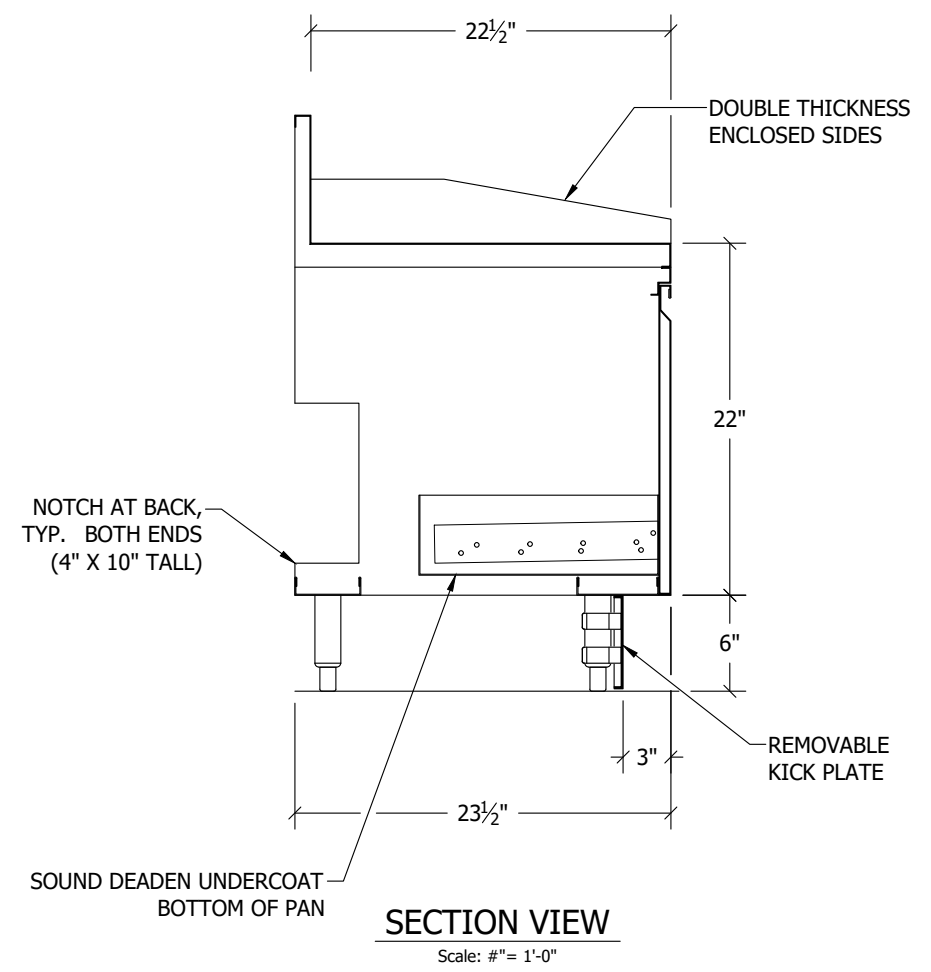

SECTION VIEW

Scale: # = 1'-0"

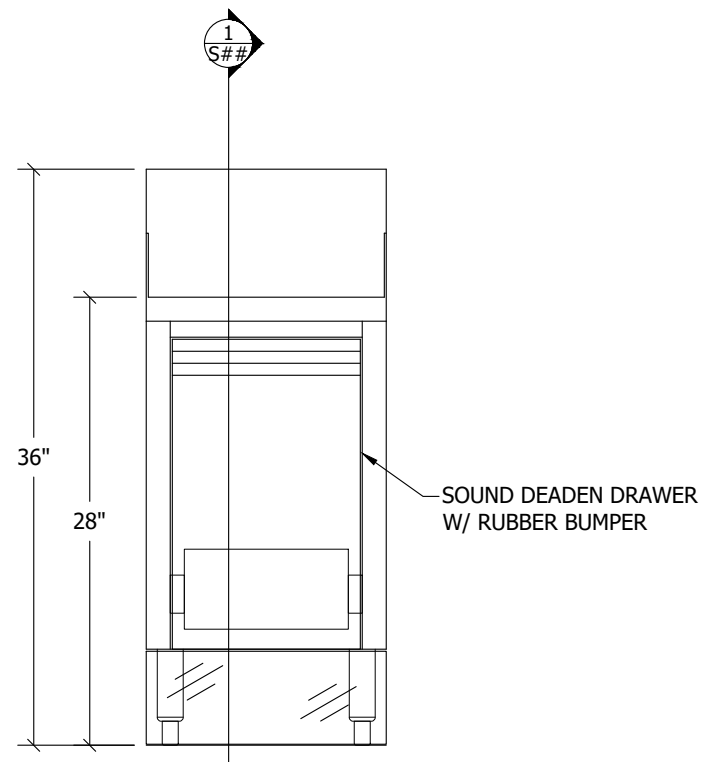

FRONT VIEW

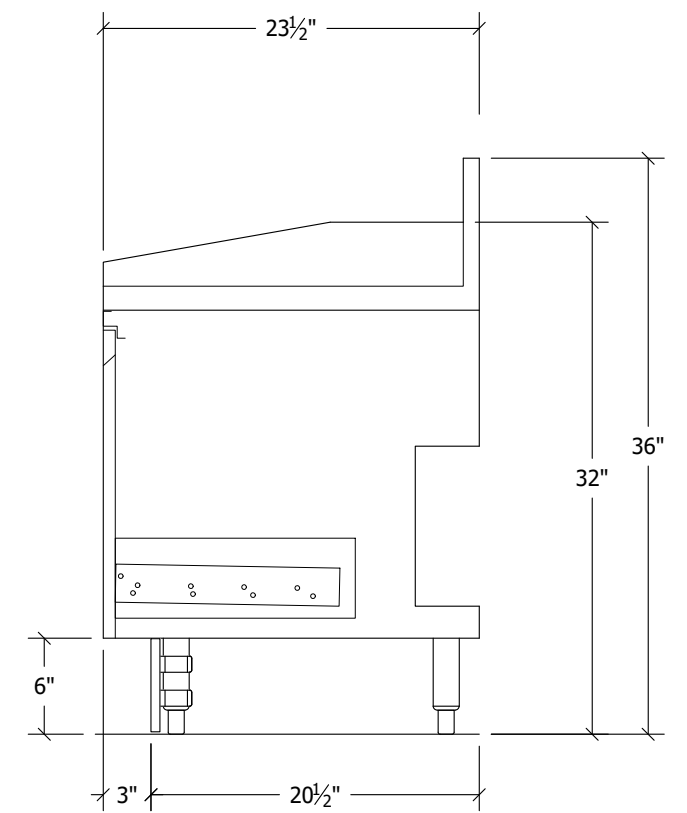

SIDE VIEW

..(Revit Families (Current))Eurobar logo.png

CUSTOMER:

ITEM NO: **EBFSU15**
MAIN SCALE: 1
SECTION SCALE: 1
EUROBAR
MASTER DRAWING
11x17 PAGE FORMAT

31

REVISIONS

Proj. Mgr:
Drawn By:
Drawn Date: