

EBIBW12 - BOTTLE WELL

ITEM ##### - SCALE: # = 1'-0"

1 EACH

MATERIALS & FINISHES

(WHERE APPLICABLE)

- WORKING SURFACE & TUB(S): 16GA 304 SERIES S/S, #4 FINISH
- PERFORATED INSERT: 18GA 304 SERIES S/S, #4 FINISH
- UNDERSTRUCTURE: 16GA GALVANIZED
- CABINET BODY & FLOOR SHELF: 18GA S/S, #4 FINISH
- LEGS: ϕ 1-5/8" 16GA S/S TUBING & ADJ. BULLET FEET
- DRAIN(S): BY EUROBAR
 - ϕ 1" BRASS DRAIN, 1" NPT, 3/4" TALL - QTY (1)
- MOUNTING CLIPS: 1 EA PER 24" OF BACKSPLASH

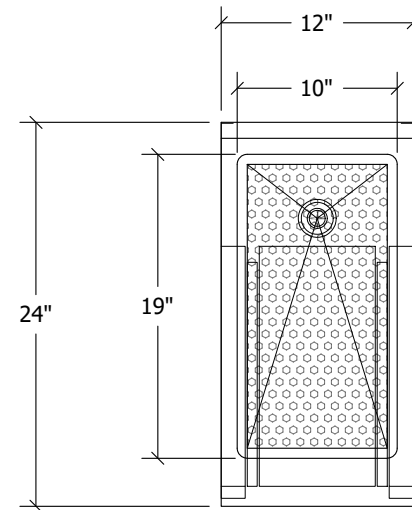

PLAN VIEW

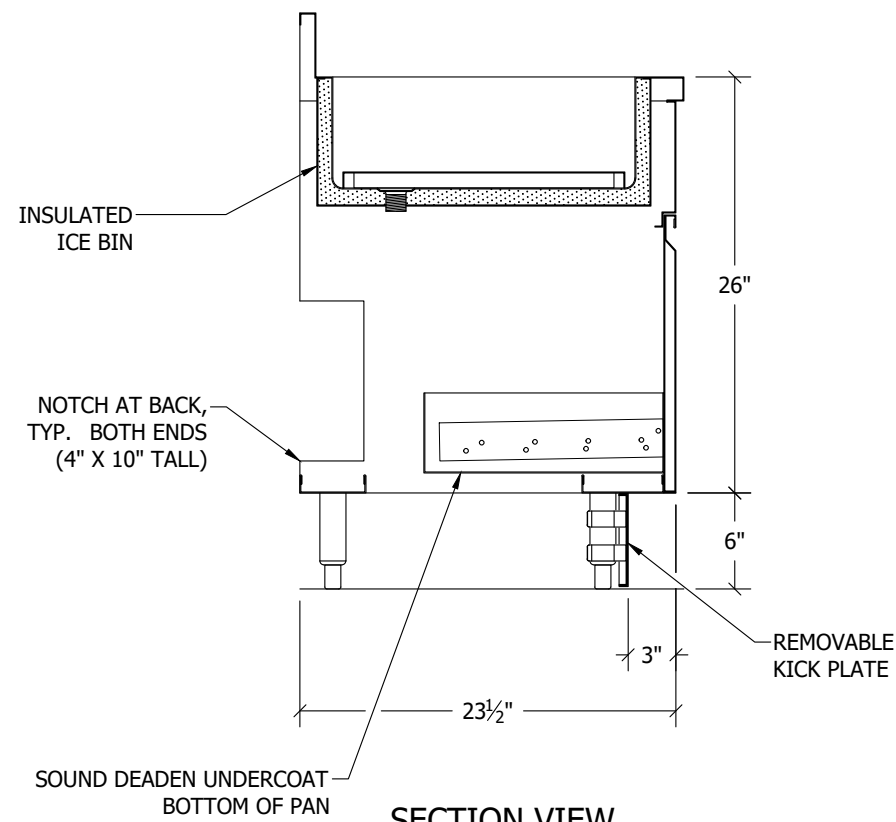

SECTION VIEW

Scale: # = 1'-0"

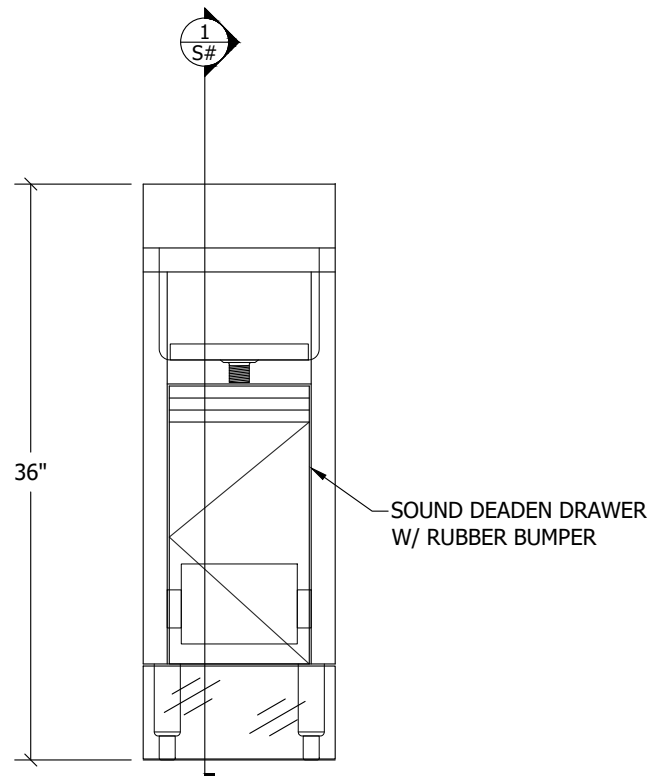

FRONT VIEW

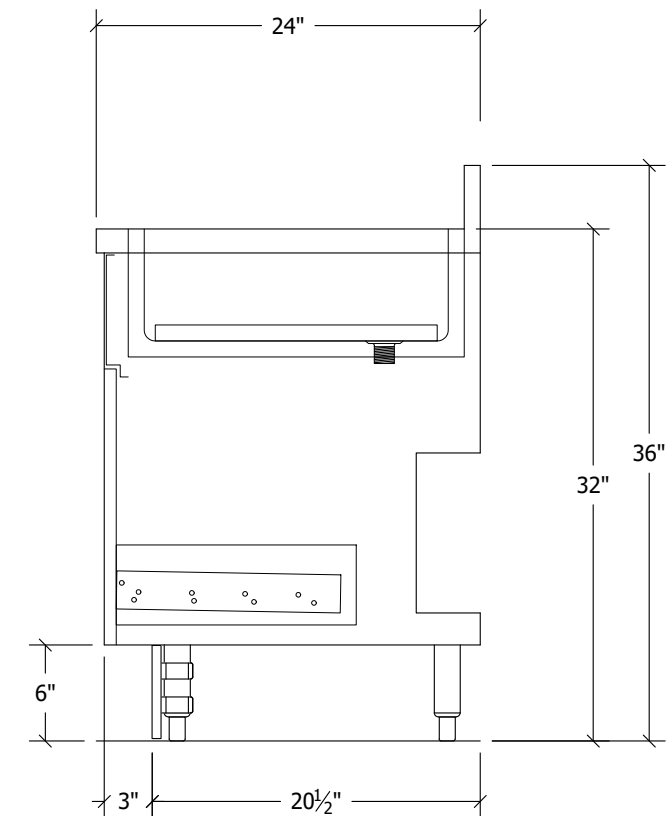

SIDE VIEW

CUSTOMER:

ITEM NO: **EBIBW12**
 MAIN SCALE: **1**
 SECTION SCALE: **1**

8

REVISIONS

Proj. Mgr:
 Drawn By:
 Drawn Date: