

MATERIAL BUY-OUT LIST					
ITEM #	DESCRIPTION	MAKE / PART NUMBER	QTY	SUPPLIED BY	INSTALLED BY
—	14" S/S DRAWER SLIDES	CHG / S26-0014	1	EUROBAR	EUROBAR

EBULD24 - LIQUOR STEP & STORAGE

ITEM ##### - SCALE: #" = 1'-0"

MATERIALS & FINISHES

(WHERE APPLICABLE)

- WORKING SURFACE: 16GA 304 SERIES S/S, #4 FINISH
- UNDERSTRUCTURE: 16GA GALVANIZED
- CABINET BODY: 18GA S/S, #4 FINISH
- DRAWER(S): 18GA S/S, #4 FINISH
- SOUND DEADEN UNDERCOAT REQUIRED AT BOTTOM OF DRAWER PAN ONLY (SEE NOTE BELOW)
- LEGS: ϕ 1-5/8" 16GA S/S TUBING & ADJ. BULLET FEET
- MOUNTING CLIPS: 1 EA PER 24" OF BACKSPLASH

1 EACH

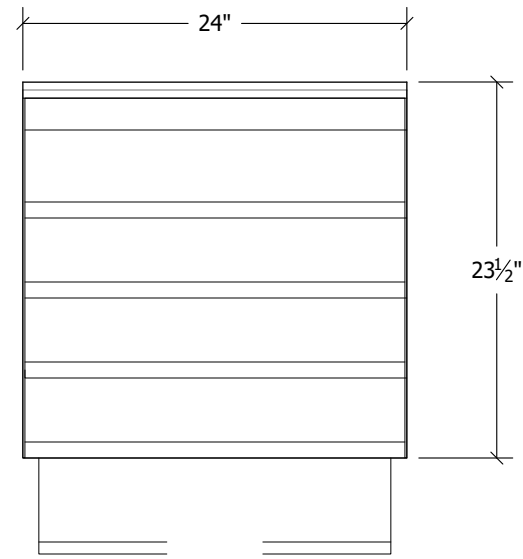

PLAN VIEW

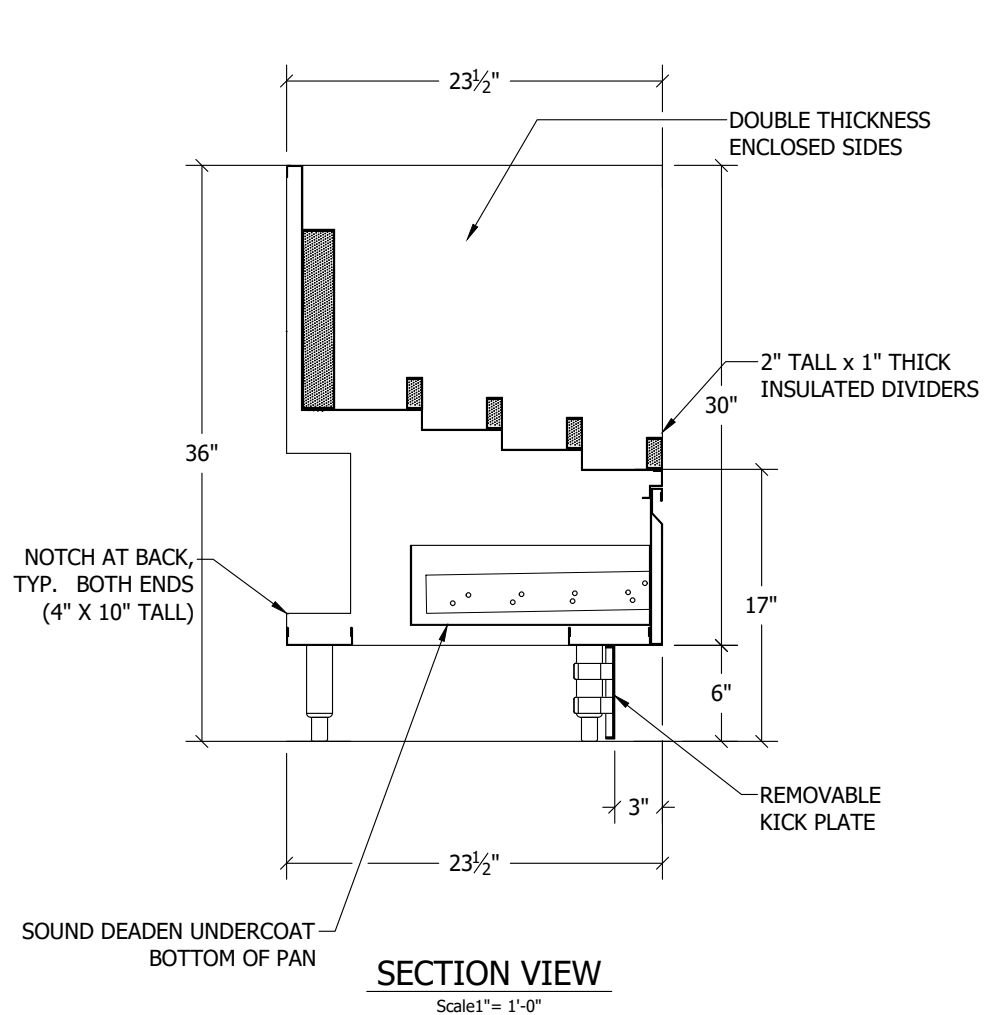

SECTION VIEW

Scale1" = 1'-0"

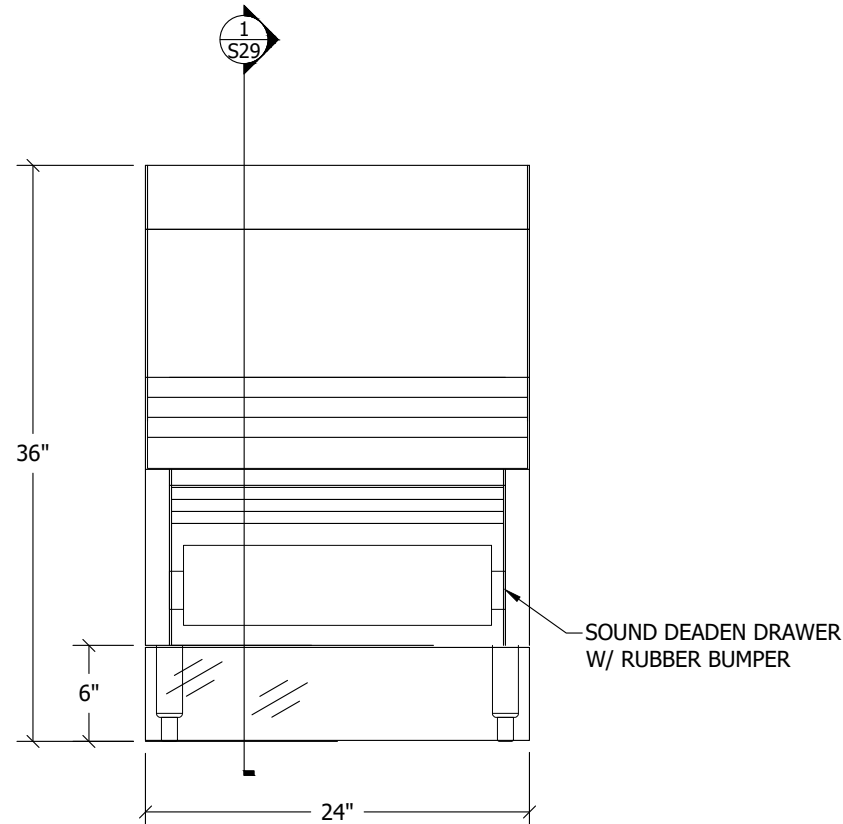

FRONT VIEW

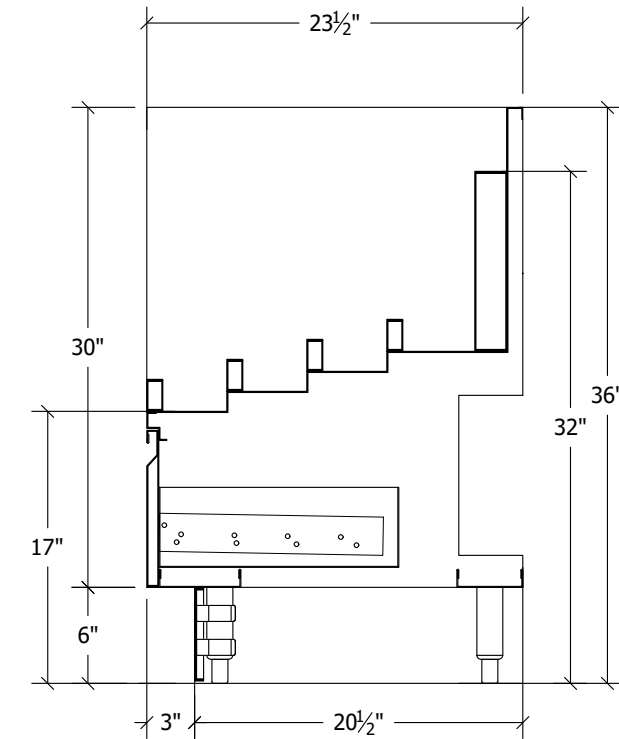

SIDE VIEW

..\\Revit Families (Current)\Eurobar logo.png

CUSTOMER:

ITEM NO: **EBULD24**
EUROBAR
 MASTER DRAWING
 1.1x17 PAGE FORMAT

29
 MAIN SCALE: 1
 SECTION SCALE: 1

REVISIONS

NO.	DESCRIPTION

Proj. Mgr:	
Drawn By:	
Drawn Date:	